

4

3

2

1

REVISION DATA

REV	DESCRIPTION	DATE
A0	NEW DRAWING	2011-04-21

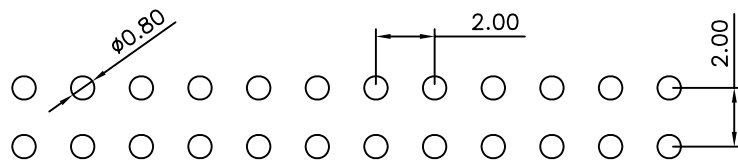
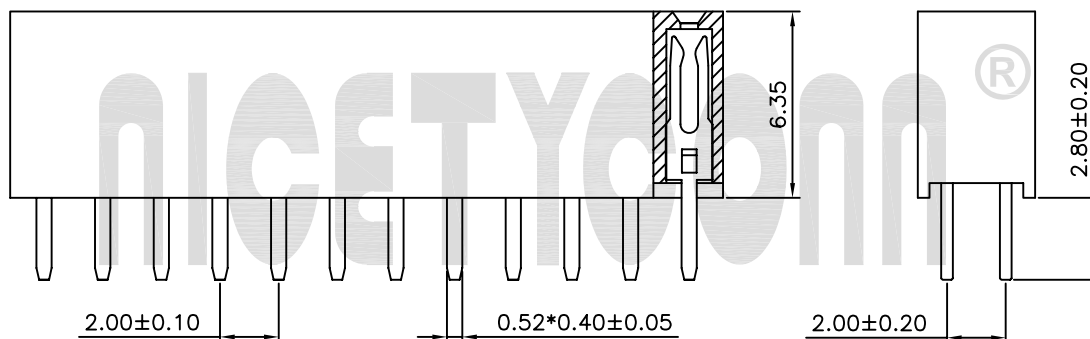
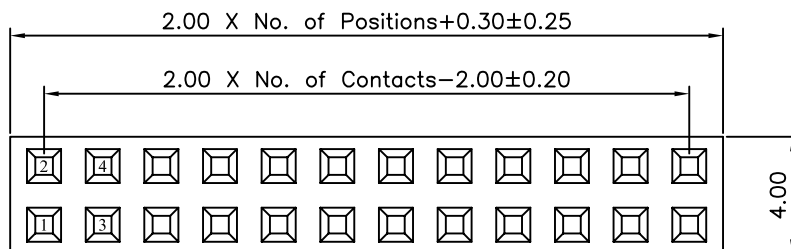

P.C.B LAYOUT

Technical Data

Material:

Contact Material: Brass

Contact plating: Au or Sn Over 50μ" Ni

Insulator Material: Black Polyester UL94V-0

Standard: PA6T+30%G.F

Electrical:

Current rating: 2.0Amps/contact max.

Contact resistance: ≤20mΩ/contact

Insulation resistance: ≥1000MΩ at V=100V

Withstanding Voltage: 500V AC/minute

Mechanical:

Mechanical life cycle: min.200

Operating temperature: -40°C to +105°C

Soldering temperature: +255°C

PM	2	63	12	XXX	D	XX	X	N	Y	028
----	---	----	----	-----	---	----	---	---	---	-----

品名 PM=排母	间距 2=2.0mm	塑高 63=6.35mm	产品类型 12=单塑双排	PIN位总数 04~80P	产品折弯类型 D=直插	表面处理 SN Tin100u" GF Gold Flash G1 Gold 1u" G2 Gold 2u" G3 Gold 3u" G4 Gold 5u" G5 Gold 8u" G6 Gold 10u" G7 Gold 15u" G8 Gold 30u"	塑胶材质 A=PBT C=PA6T	塑胶特性 N=常规	塑胶类型 Y=Y型	端子PC/脚宽
-------------	---------------	-----------------	-----------------	------------------	----------------	---	-------------------------	--------------	--------------	---------

nicetycomm 深圳市创辉诚科技有限公司
SHENZHEN CHUANGHUICHENG TECHNOLOGY CO.,LTD

TOLERANCE	PROJECTON		TITLE:
ANGLE ±5°	DATE :	2011-04-21	双排180度排母 PH2.0 H6.35 Y型 PC2.8
X.XXX ±0.10	DRAWN :		PART NO: PM26312XXXDXXXNY028
X.XX ±0.20	CHECKED :		DRAWING NO: PM26312DY073
X.X ±0.30	APPROVED :		REV: A0 UNIT: mm SCALE: 3:1 SIZE: A4
X. ±0.50			

4

3

2

1