

4 3 2 1

REVISION DATA		
REV	DESCRIPTION	DATE
A0	NEW DRAWING	2011-06-21

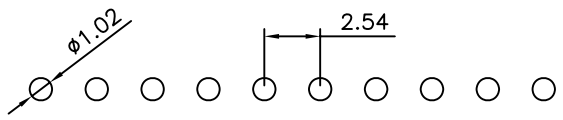
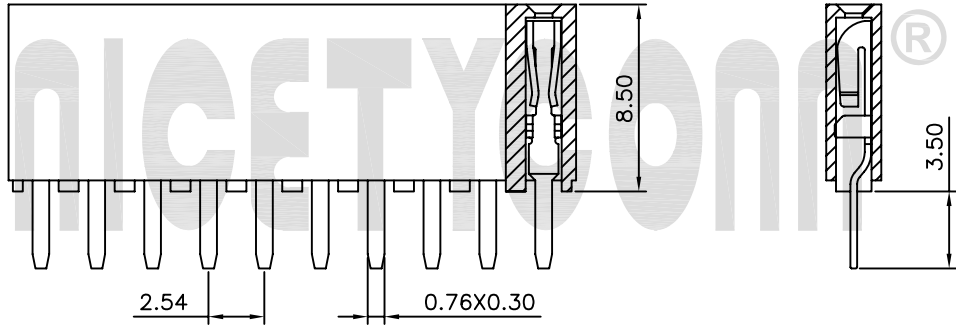
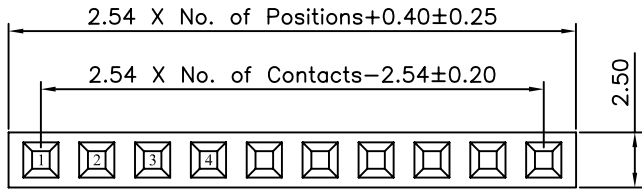

P.C.B LAYOUT

## Technical Data

**Material:**  
 Contact Material: Phosphor Bronze  
 Contact plating: Au or Sn Over 50μ" Ni  
 Insulator Material: Black Polyester UL94V-0  
 Standard: PBT/PA6T+30%G.F

**Electrical:**  
 Current rating: 3.0Amps/contact max.  
 Contact resistance: ≤20mΩ/contact  
 Insulation resistance: ≥1000MΩ at V=100V  
 Withstanding Voltage: 1000V AC/minute

**Mechanical:**  
 Mechanical life cycle: min.200  
 Operating temperature: -40°C to +105°C  
 Soldering temperature: +255°C

PM	1	85	11	XXX	D	XX	X	N	O	035
品名 PM=排母	间距 1=2.54	塑高 85=8.5mm	产品类型 11=单塑单排	PIN位总数 02~40P	产品折弯类型 D=直插	表面处理 SN Tin100u" GF Gold Flash G1 Gold 1u" G2 Gold 2u" G3 Gold 3u" G4 Gold 5u" G5 Gold 8u" G6 Gold 10u" G7 Gold 15u" G8 Gold 30u"	塑胶材质 A=PBT C=PA6T	塑胶特性 N=常规	塑胶类型 O=O型	端子PC/脚宽

**nicetycomm®** 深圳市创辉诚科技有限公司  
 SHENZHEN CHUANGHUICHENG TECHNOLOGY CO.,LTD

TOLERANCE	PROJECTON		TITLE: 单排母座180度 PH2.54 H8.5 O型 PC3.5
ANGLE ±5°	DATE :	2011-06-21	PART NO: PM18511XXXDXXXNO032
X.XXX ±0.10	DRAWN :		DRAWING NO: PM18511DO032
X.XX ±0.20	CHECKED :		REV: A0 UNIT: mm SCALE: 3:1 SIZE: A4
X.X ±0.30	APPROVED :		
X. ±0.50			

4 3 2 1